



Acceleration

H. Padamsee

Muon acceleration challenges

Large phase space at muon source
large emittance and energy spread
Short lifetime.

Key technical issues

Choice of acceleration technology
Superconducting vs. normal conducting
RF frequency choice

Choice of acceleration scheme (architecture)
How to capture, accelerate, transport to
storage ring

Accelerator performance issues
potential collective effects
e.g., cumulative beam breakup from the high
peak current.



Choices Made

201.25 MHz

Large acceptances needed

Beam is already bunched at 201.25 MHz at the source (ionization cooling)

SRF cavities offer attractive solution.

Short muon lifetime demands high gradients

Copper structures would require very peak power of RF sources.

SRF: 15 - 17 MV/m (active length) possible

=> Real estate gradient of 7 - 7.5 MV/m.

SRF can be filled slowly & long pulses (2 - 3 msec)

-RF source peak power can be reduced.

-Accelerate multiple passes of bunch train

SRF cavity apertures can be significantly larger.

low impedances good for beam stability

High stored energy at 201.25 MHz

and long pulse length for multiple passes

Affordable



Acceleration scheme

Muon survival demands (no rings)
high-gradient linac or recirculating linac

Recirculation provides cost savings
but not possible at low energy

Beam is not sufficiently relativistic
=> phase slip for beams in higher passes
reduces acceleration efficiency

Difficulties with injection of a beam of large
emittance and energy spread.
=> Linear accelerator to about 2.5 GeV

RLA

Cost considerations favor multiple passes but

Experience at Jefferson Lab suggests that for
large initial emittance and energy spread,
ratio of final-to-injected energy below 10-to-1 is
prudent =>

number of passes should be limited to about 4-5



Machine architecture (Figure)

0.19-to-2.48 GeV “preaccelerator” linac,

2.48-to-20 GeV four pass recirculating linac (RLA).
(Figure)

Loss of muons during acceleration.
(Figure)

Cryomodule and cavity architecture
(Figures)

Power coupler technology
(Figure)

Best 380 kW CW to beam achieved at 500 MHz KEK-B
use one coupler per cell - 500 kW (pulsed)

Machine Architecture

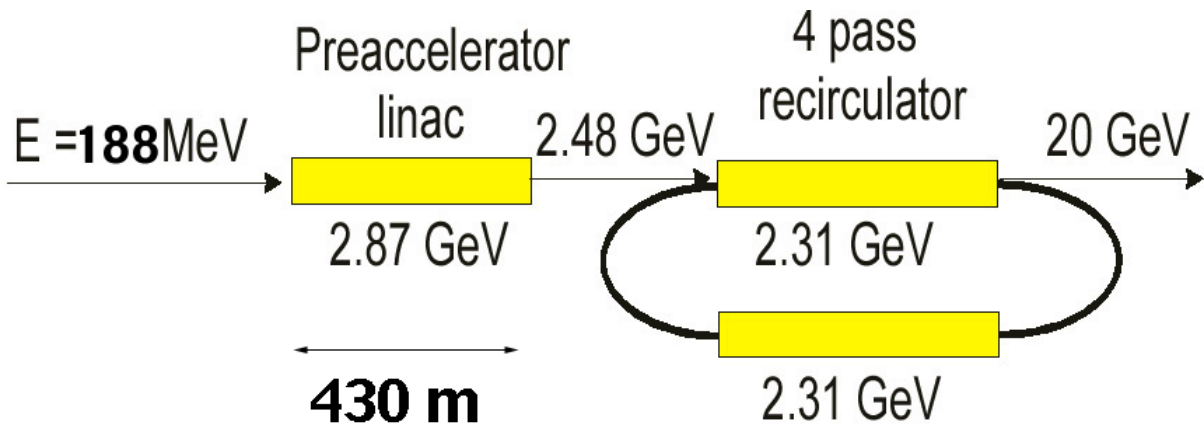

Figure 1. Layout of the muon accelerator driver

Table 1. Main Parameters of the Muon Accelerator Driver

Injection momentum/Kinetic energy	210/129.4 MeV
Final energy	20 GeV
Initial normalized acceptance	15 mm·rad
rms normalized emittance	2.4 mm·rad
Initial longitudinal acceptance, $\Delta p L_b / m_\mu$	170 mm
momentum spread, $\Delta p / p$	± 0.21
bunch length, L_b	± 407 mm
rms energy spread	0.084
rms bunch length	163 mm
Number of bunches per pulse	67
Number of particles per bunch/per pulse	$4.4 \cdot 10^{10} / 3 \cdot 10^{12}$
Bunch frequency/accelerating frequency	201.25/201.25 MHz
Average repetition rate	15 Hz
Time structure of muon beam	6 pulses at 50 Hz with 2.5 Hz repetition rate
Average beam power	150 kW

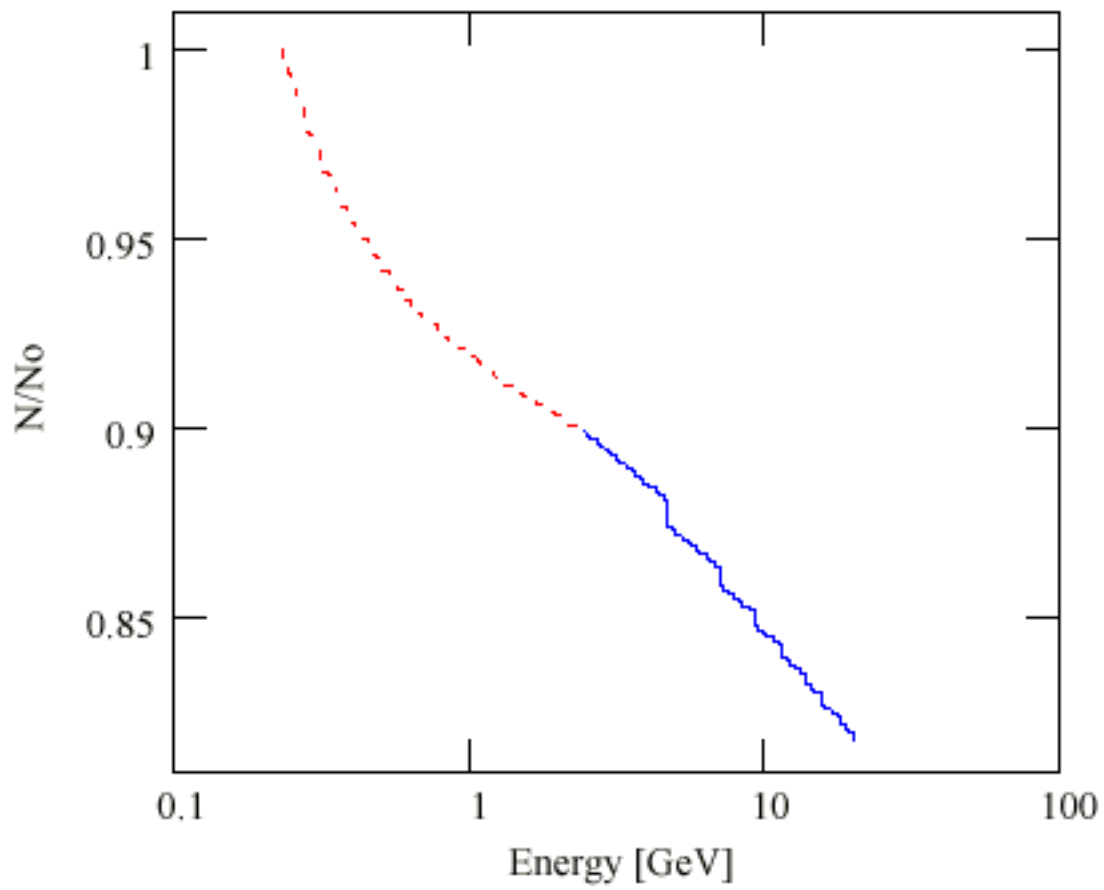
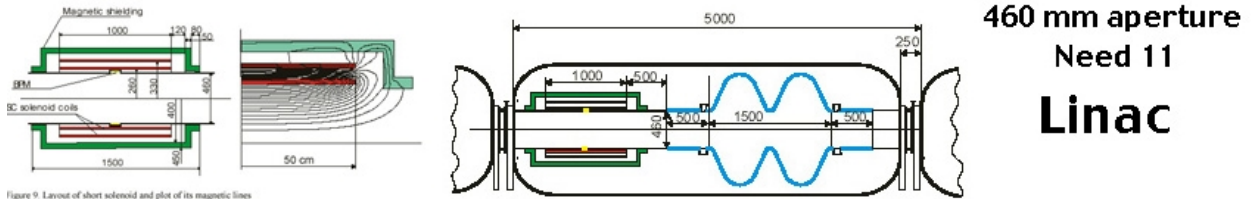
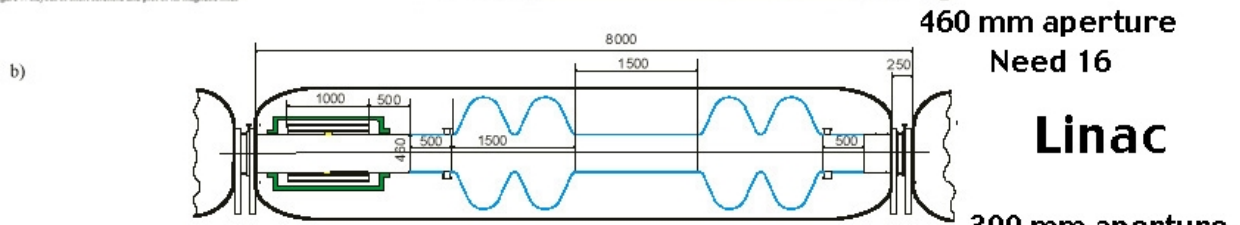

Figure 2. Decay of muons in the course of acceleration;

Cryomodule and Cavity Architecture



460 mm aperture
Need 11
Linac



460 mm aperture
Need 16

Linac

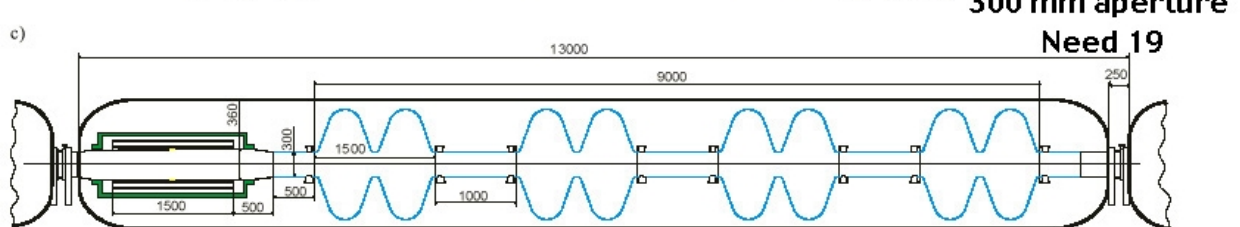

300 mm aperture
Need 19

Figure 3. Layouts of a) short, b) intermediate-length, and c) long cryo-modules. Blue lines present SC walls of cavities. Solenoid coils are marked by red color, and BPMs by the yellow.

Linac

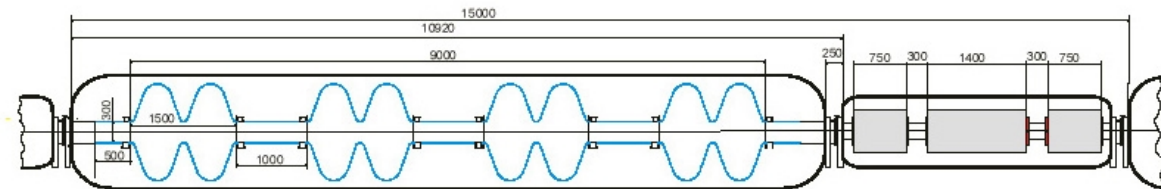
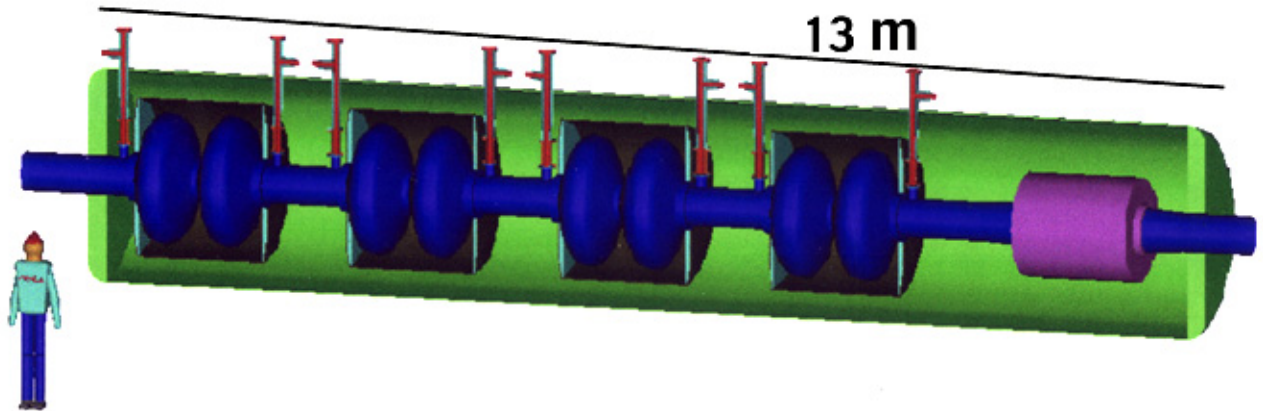

Figure 28. Layout of RLA linac period.

RLA

300 mm aperture
Need 48

Typical Cryomodule and Coupler



Cryomodule, Input coupler, HOM coupler, tuner
Need Development

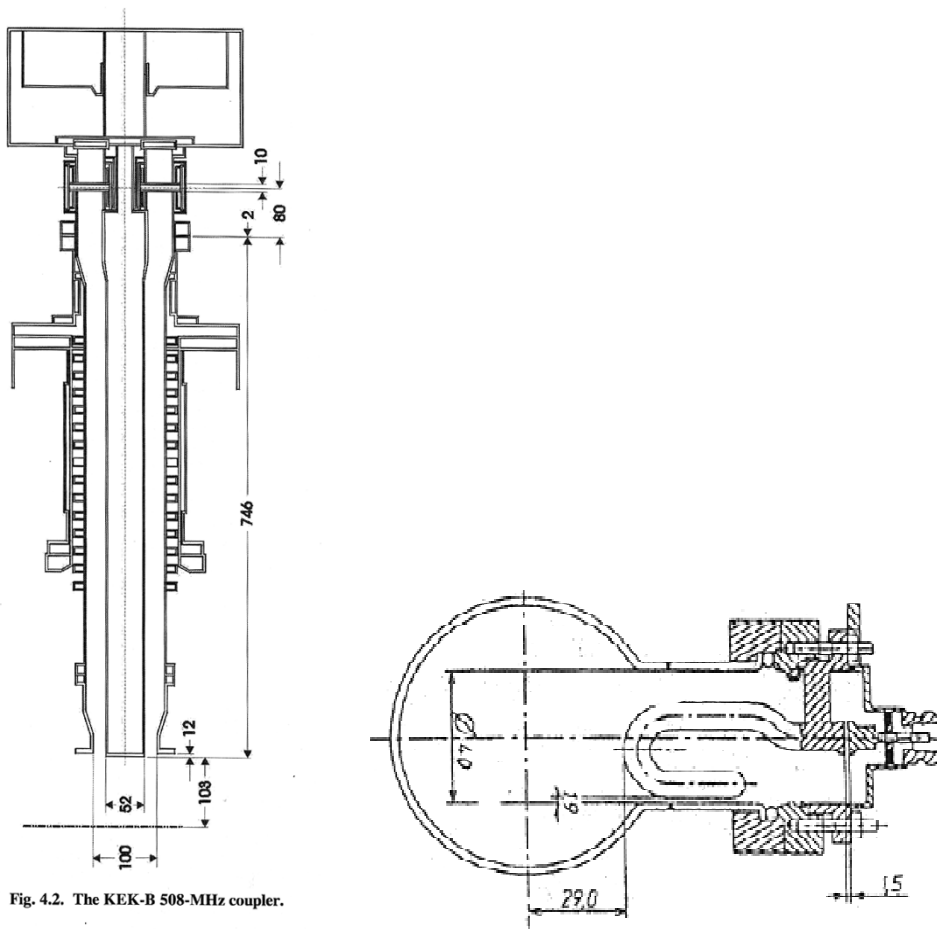

Fig. 4.2. The KEK-B 508-MHz coupler.



SRF Technology

Science and technology highly developed for cavities and associated technologies (i.e. couplers, tuners, cryomodules)

Substantial operating experience at TRISTAN, HERA
CEBAF, LEP-II, CESR, KEK-B and TTF

SRF systems totaling one km in active length installed and operated to provide a total of 5 GV.

Largest installation : LEP-II
500 m of niobium-coated-copper cavities provide more than 3 GV of acceleration.

NuFactory calls for 500 m to provide 7.4 GV.



Choose LEP-II based Nb/Cu technology

TESLA sheet metal niobium cavities
provide gradients of 20 MV/m and higher

BUT

201.25 MHz RF frequency, large scale
e.g. 6 mm wall thickness
cost of raw sheet niobium becomes prohibitive
(> 100 M\$ at \$500/kg) for 600 cells

Wall thickness may need to be > 6 mm
mechanical stability against atmospheric load
Lorentz force detuning
microphonics from external vibrations.

One kilo-joule stored energy per cell
High thermal conductivity copper
better stability against quenches

Lower RF losses in ambient DC magnetic field
(less shielding needed)

Coated copper cavity allows pipe cooling instead of bath cooling.

save liquid helium inventory

(estimated at 100,000 Liters for standard bath cooling of 600 cells).

Pipes open additional avenues for improving the mechanical stability for large scale cavities.



Proof of principle
CERN LHC 400 MHz Nb/Cu cavities

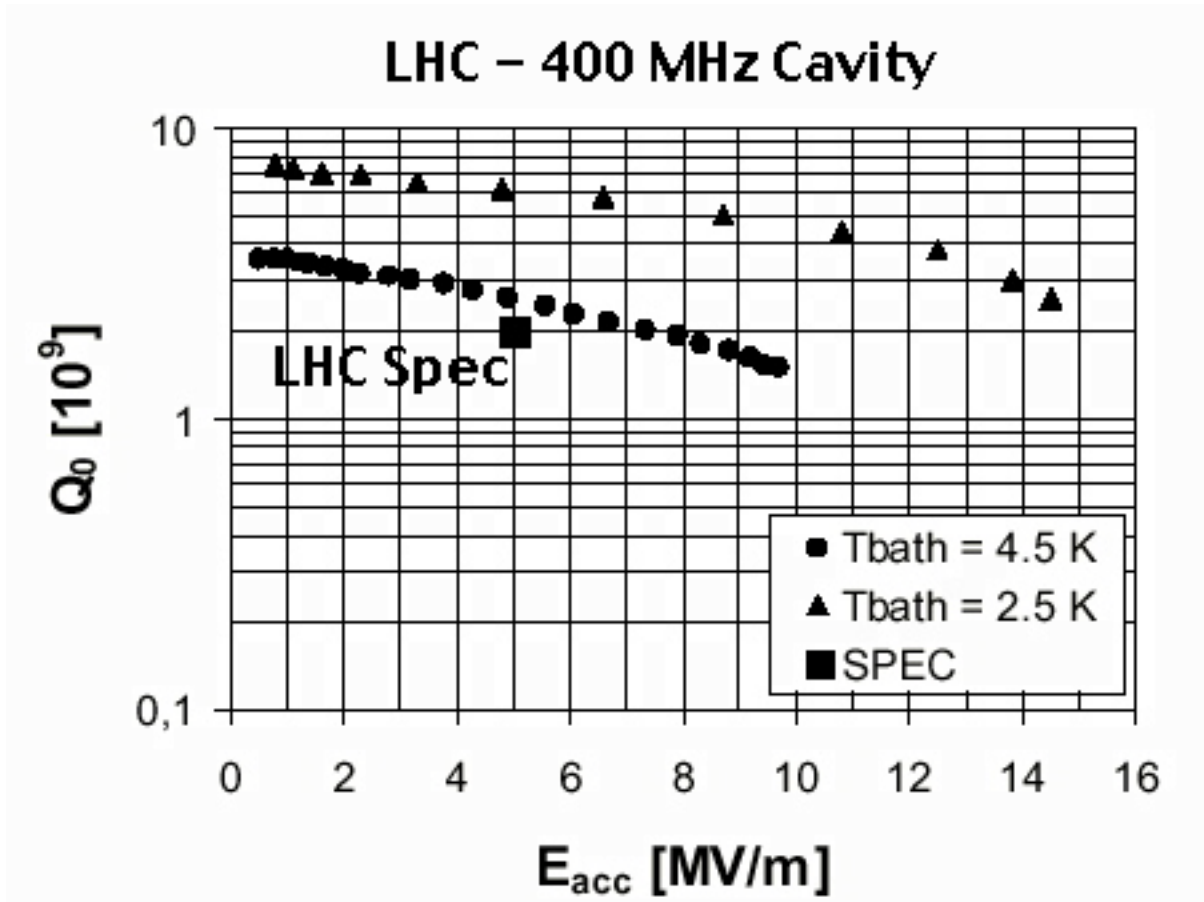

Reached accelerating gradients
15 MV/m at 2.5 K at a Q of 2×10^9



Expected performance at 201.25 MHz

201.25 MHz => higher Q

Improved structure geometry => Lower peak fields

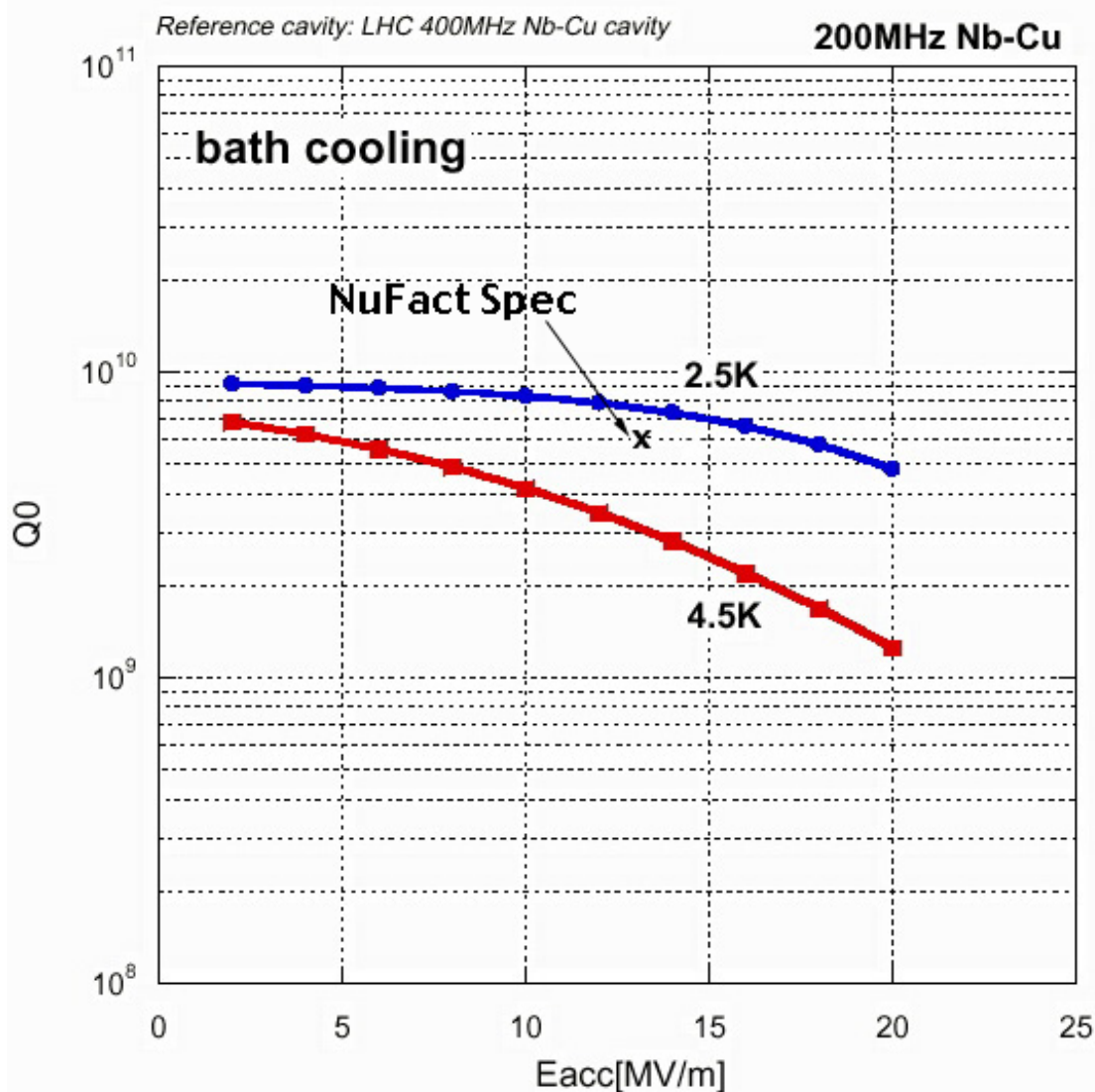



Overall Parameters for NuFactory SRF

No. of cryomodules	9 4
No. of 2-cell cavities	3 1 1
No. of input couplers	6 2 2
Overall length	1061 m
Active length	467 m
Filling factor	0.44
Total voltage	7.5 GV
Average Real Estate Gradient	7.4 MV/m
Total heat load @2.5, 5-8, 40 - 80 K	7.4, 9.4, 94 kW
Cryo load with x 1.5 safety factor 2.5, 5-8, 40 - 80 K	11.1, 14.1, 14 kW
Assuming efficiency multipliers of 225 , 20	
AC power for refrigeration	12.6 MW
Total peak RF power with 20% ma for control/losses	362 MW
Average RF power	16.3 MW
AC Power for RF (efficiency multiplier =	35.6 MW
Total AC Power	48 MW



R&D Needed

History of SRF development for LEP, CEBAF, CESR, KEK-B and TTF (TESLA) shows

It takes many years to design, prototype and test new structures in order to be ready.

R&D and prototyping for a Neutrino Factory at 201.25 MHz should be started at least five years in advance.

It is started now

Lowest SRF frequency used to date is 350 MHz for LEP-II.

Need to demonstrate performance for large scale 201.25 MHz cavity



R&D in Progress

- Aim for 17 MV/m at Q of 6×10^9
in a single cell 201.25 MHz cavity

CERN is making cavity

Cornell is getting ready to test
cryostat, radiation shielded test pits, clean room
(Figure)

Reduce structure cost
collaboration with INFN, spinning monolithic
cavities

Explore pipe cooling to

- reduce liquid He inventory
- stiffen multi-cell structures

Newman SRF B50 Wed Mar 14 12:30:02 2001

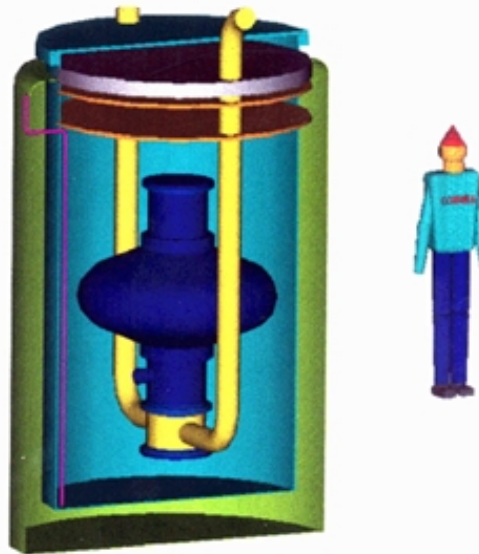
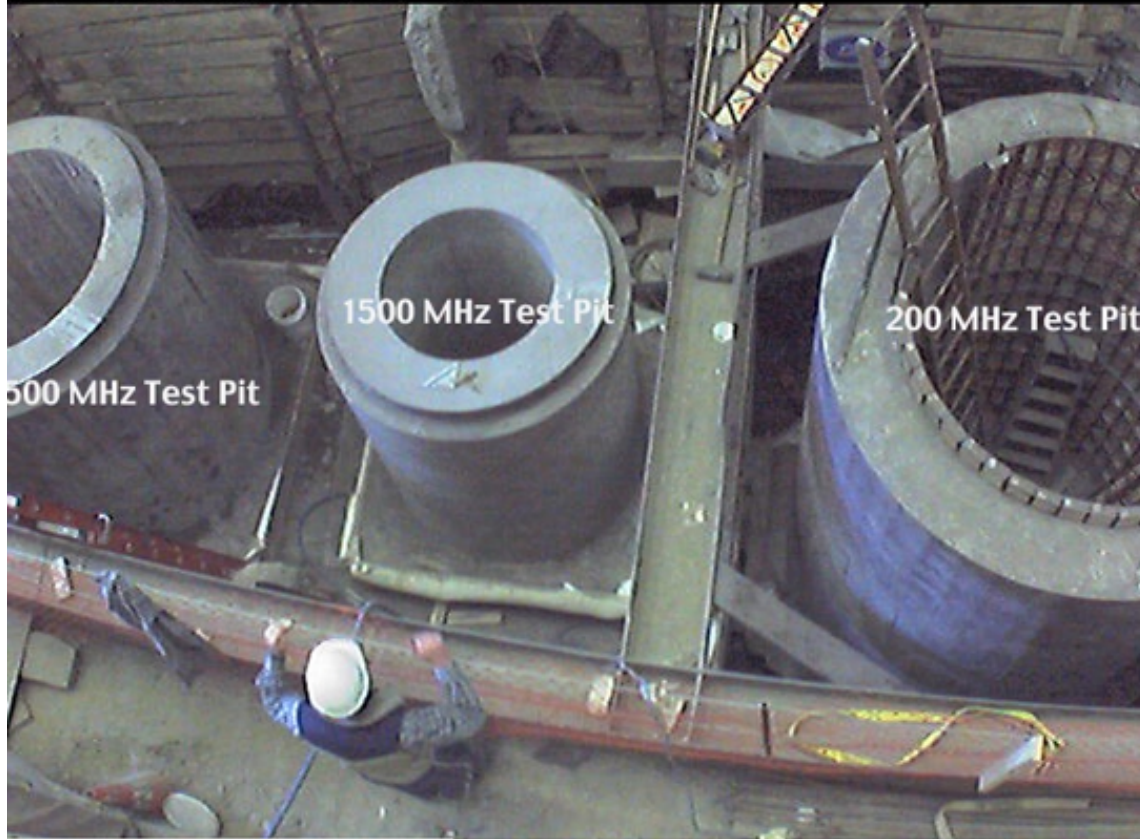

CERN Cavity and Cornell Test Pits



NSF Funded On-going R&D Cornell (Organizing Institute)

University Based Accelerator Physicists
- broad expertise needed

Cornell – Ionization Cooling (IC), High gradient acceleration

U. of Chicago- IC

Columbia U -IC

Northern Illinois U - IC

Illinois Institute of Technology - IC

U. of Illinois, Urbana-Champaign-IC

Indiana U – IC and Emittance Exchange Studies

Michigan State U – Radiation Environment Evaluation, Non-Linear Dynamics in Muon Storage Ring and Acceleration

U. of Mississippi - IC

Northwestern U -IC



Required R&D and Prototyping

Longer Term Goal:

Design, construct and high-power test a cryomodule with the first single cell 201.25 MHz cavity, equipped with couplers and tuners.

Improve structure

- make exact geometry cavity
- Stiffen the 2-cell cavity designs to reduce Lorentz force detuning and microphonics sensitivity

Develop and prototype

- high-power input coupler
- higher order mode coupler
- mechanical/thermal tuner
- piezo /magnetostrictive tuner
- cryomodule
- system integration
- high-power test
 - long pulse length, 201.25 MHz, 10 MW klystron