

Muons, Inc. Status:

Six SBIR/STTR Muon Projects

Rolland Johnson, April 28, 2004

- HP HG GH2 RF
 - Ph II, w IIT, DK
- 6D Cooling on Helix
 - Ph I, w Jlab, YD
- Pulse Compression
 - Awarded, not funded
- MANX
 - Proposed w FNAL, DF
- H2 Cryostat
 - Proposed w FNAL, DF
- PIC
 - Proposed w Jlab, YD

Thanks to Excellent Collaborators

- IIT; Dan Kaplan, Tom Roberts, Katsuya Yonehara
- JLab; Slava Derbenev, Alex Bogacz, Kevin Beard
- Fermilab; Chuck Ankenbrandt, Al Moretti, Milorad Popovic
- Muons, Inc.; Bob Hartline, Moyses Kuchnir

Project 1: HP HV RF Cavities

Ph II, Dan Kaplan, IIT

- Dense GH_2 suppresses high-voltage breakdown
 - Small MFP inhibits avalanches (**Paschen's Law**)
- Gas acts as an energy absorber
 - Needed for ionization cooling
- Only works for muons
 - No strong interaction scattering like protons
 - More massive than electrons so no showers

2003 STTR Phase II Project

- To develop RF cavities, pressurized with dense hydrogen or helium gas, that are suitable for use in muon cooling and accelerator applications.
- Measurements of RF parameters (e.g. breakdown voltage, dark current, quality factor) for different temperatures and pressures in magnetic and radiation fields will be made in RF cavities to optimize the design of prototypes for ionization cooling demonstration experiments

High-Pressure RF Test Cell w Moly Electrodes at Lab G

R. E. Hartline, R. P. Johnson, M. Kuchnir
Muons, Inc.

C. M. Ankenbrandt, A. Moretti, M. Popovic
Fermilab

D. M. Kaplan, K. Yonehara
Illinois Institute of Technology

See MuCool Note 285 for paper

Mark II 805 MHz RF test cell

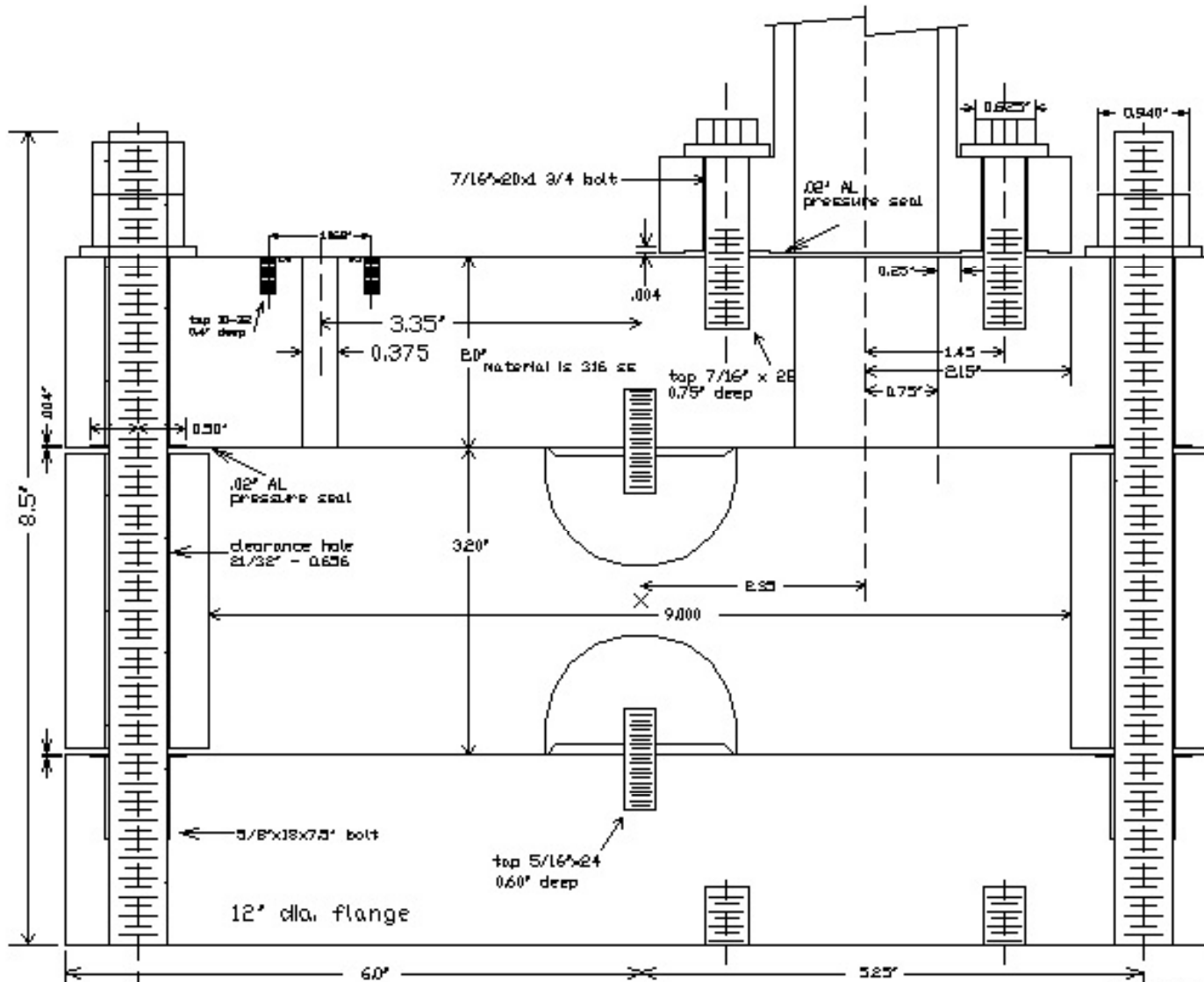

New TC; 2000PSI @ 77K



04/28/04

MUTAC BNL

7



04/28/04

MUTAC BNL

8

H2 vs He RF breakdown at 77K, 800MHz

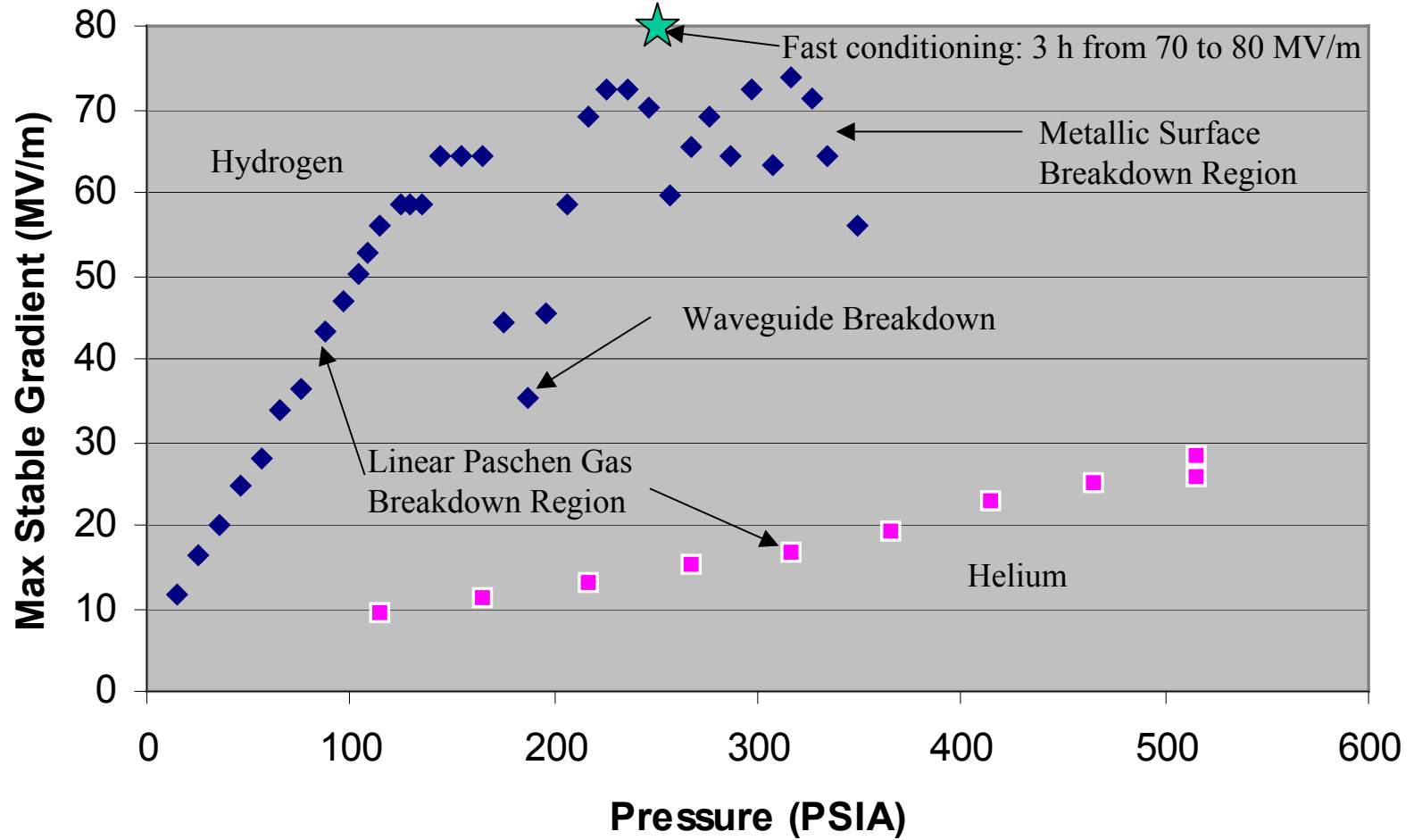

Hopes for HP GH2 RF

- Higher gradients than with vacuum
- Less dependence on metallic surfaces
 - Dark currents, x-rays diminished
 - Very short conditioning times already seen
- Easier path to closed-cell RF design
 - Hydrogen cooling of Be windows
- Use for 6D cooling and acceleration
 - Homogeneous absorber concept
 - Implies HF for muon acceleration (1.6 GHz)

Present Activities for HP RF Phase II project

- Moving from Lab G to MTA
- Studying RF breakdown with copper, molybdenum, chromium and Be electrodes
- Planning Test Cell for Operation in the LBL 5 T solenoid at 1600 PSI and 77K
- Working on MTA Beam Line
 - Want radiation test of GH2 RF in 2005

Project 2, with JLab, Derbenev Emittance Exchange With GH2

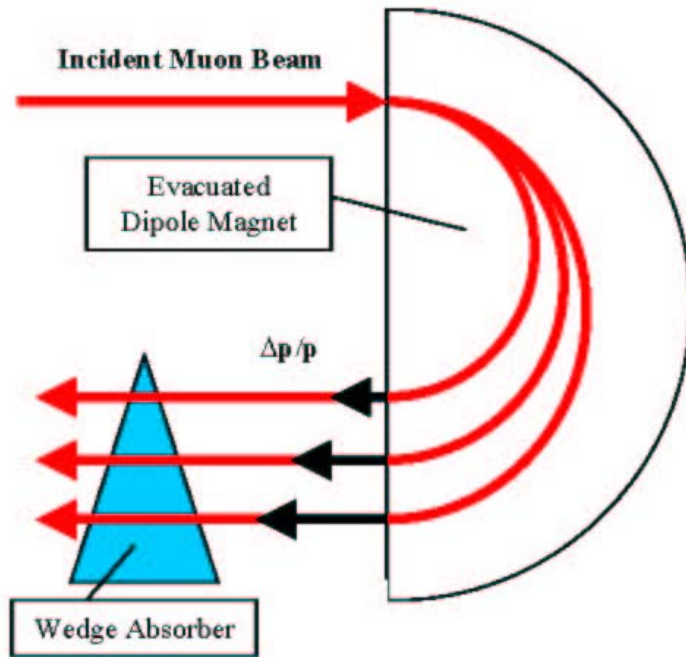

Figure 1. Use of a Wedge Absorber for Emittance Exchange

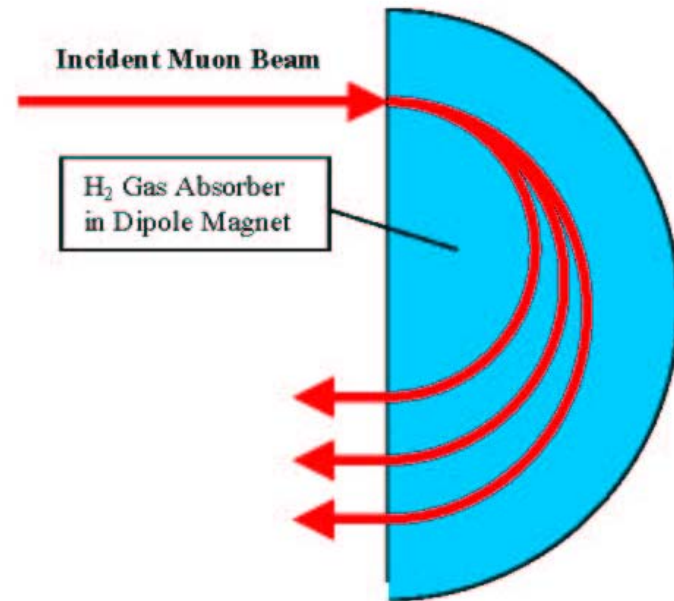

Figure 2. Use of Continuous Gaseous Absorber for Emittance Exchange

This concept of emittance exchange with a homogeneous absorber first appeared in our 2003 SBIR proposal!

6D Cooling with GH2

- Helical cooling channel (HCC)
 - Solenoidal plus transverse helical dipole and quadrupole fields
 - z-independent Hamiltonian
- Avoids ring problems
 - Injection and Extraction
 - Multi-pass Beam loading or Absorber heating
 - Fixed channel parameters as beam cools

Helical Dipole Magnet (c.f. Erich Willen at BNL)

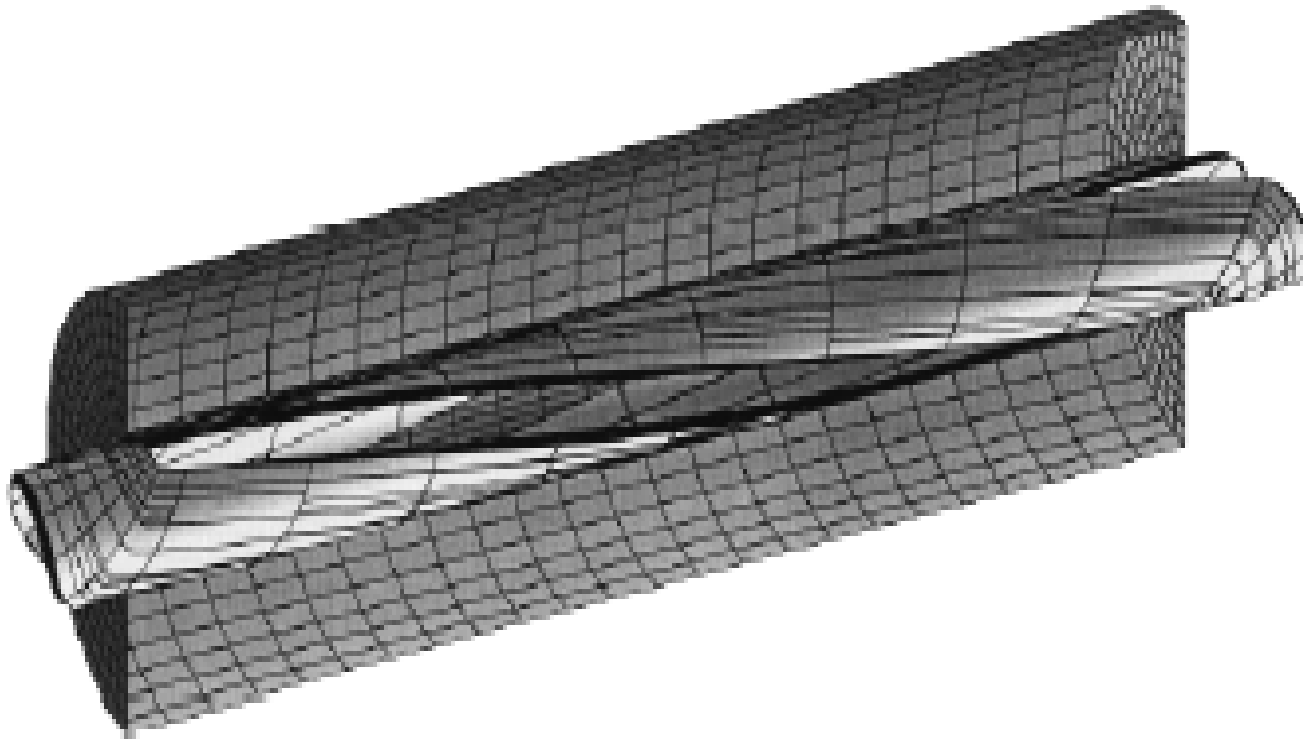

Direct Wind Type

G4BL 10 m helical cooling channel

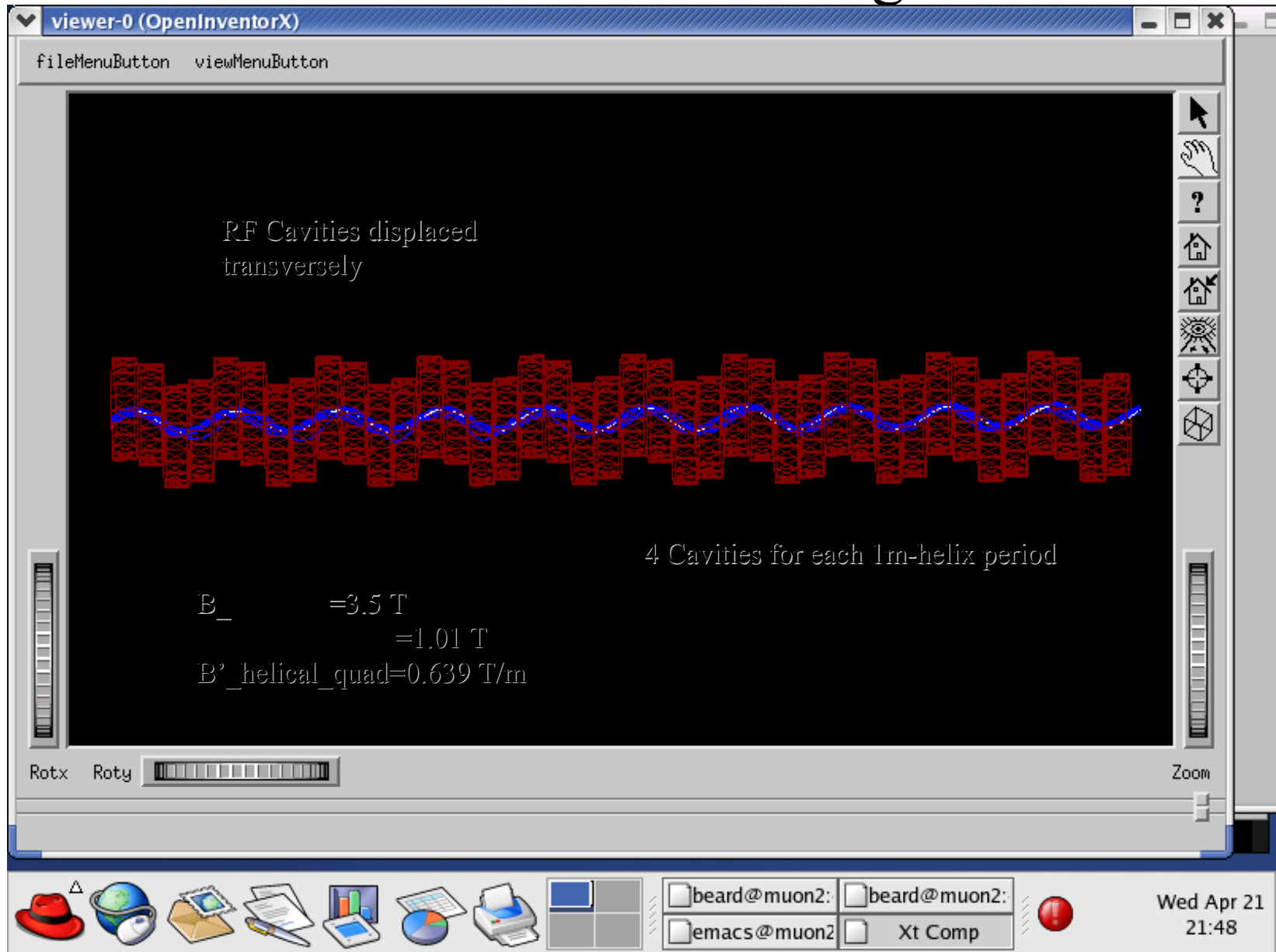

G4BL End view of 200MeV HCC

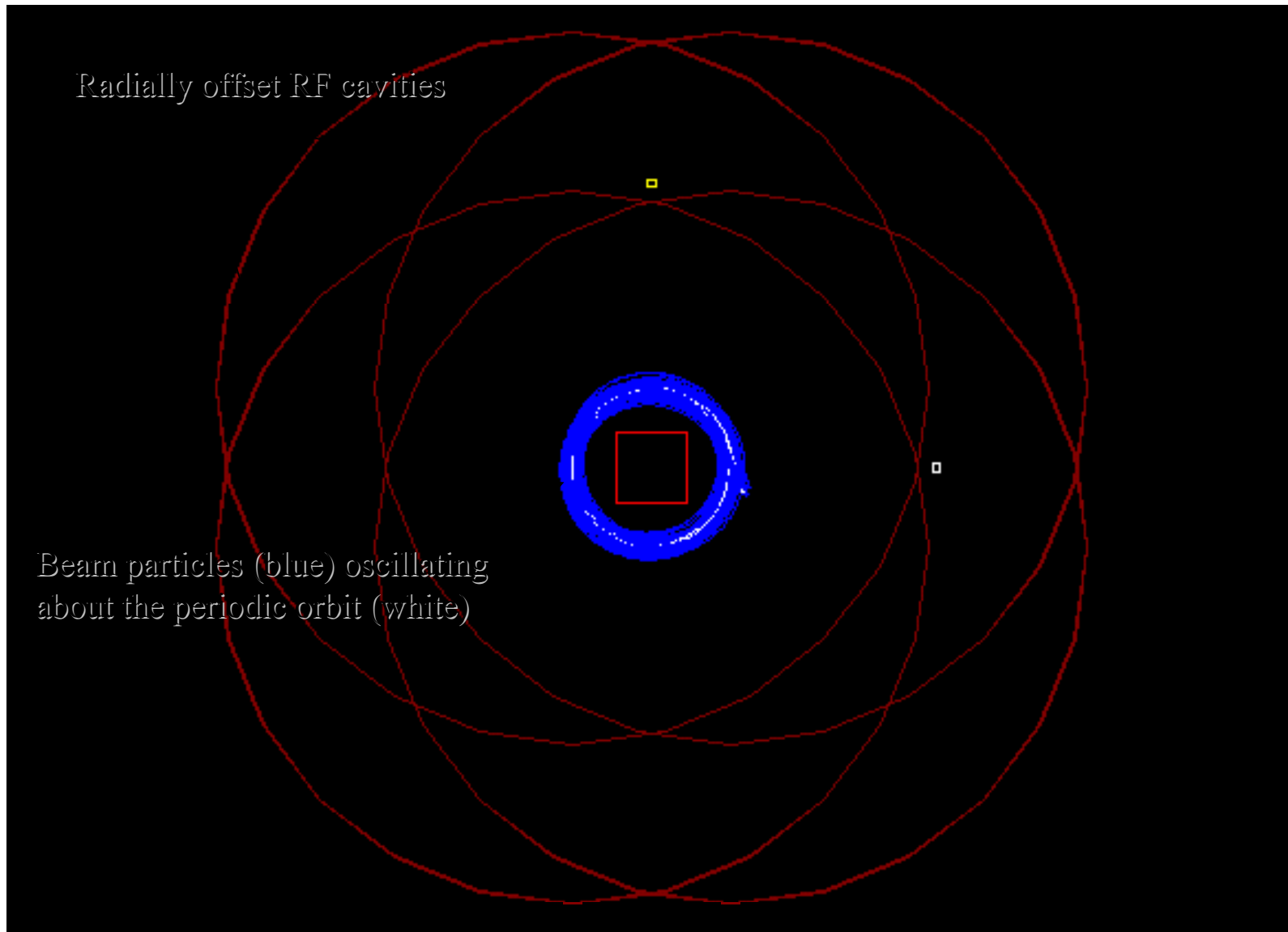

G4BL HCC Dispersion Measurement:

$$r_{250} = (1+0.25D) r_{200}, D=2.93$$

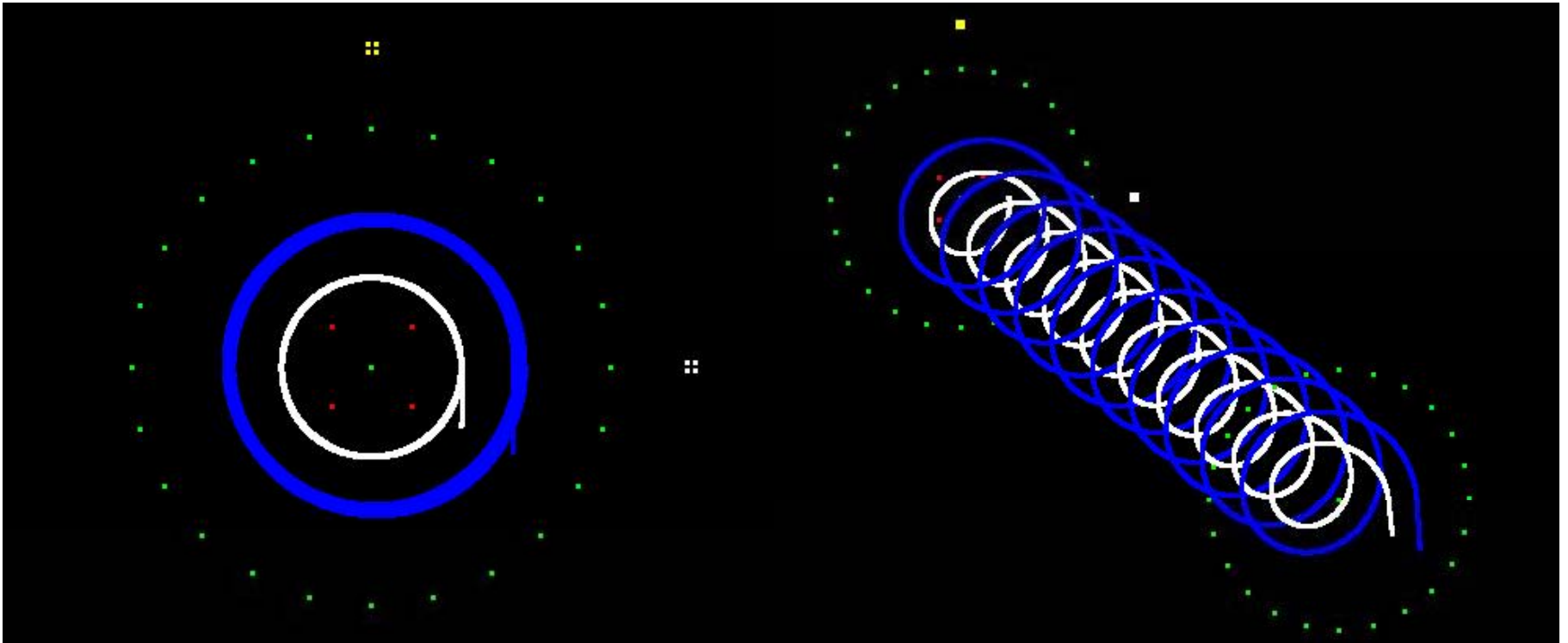

200MeV/c (white), 250 MeV/c (blue) periodic orbits

ICOOOL Simulation: HCC with dE/dx but without multiple scattering or straggling

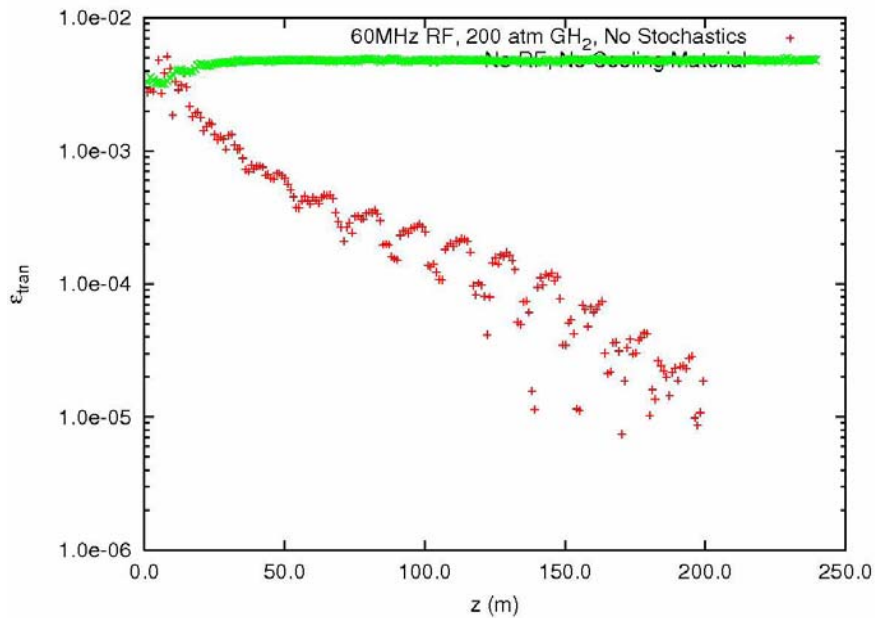

Transverse emittance

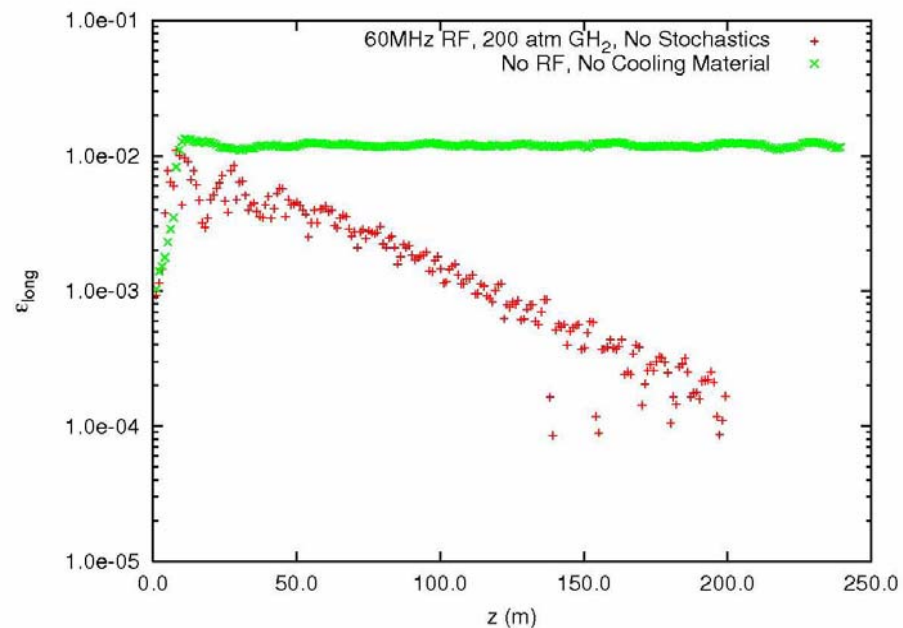

Longitudinal emittance

ICOOOL Simulation: HCC with dE/dx and multiple scattering or straggling (stochastics)

Transverse emittance

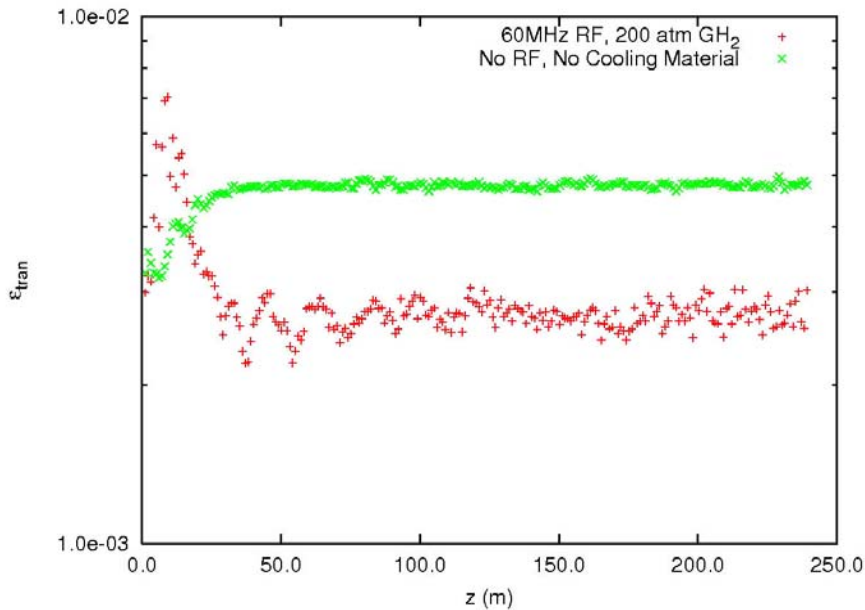

Longitudinal emittance

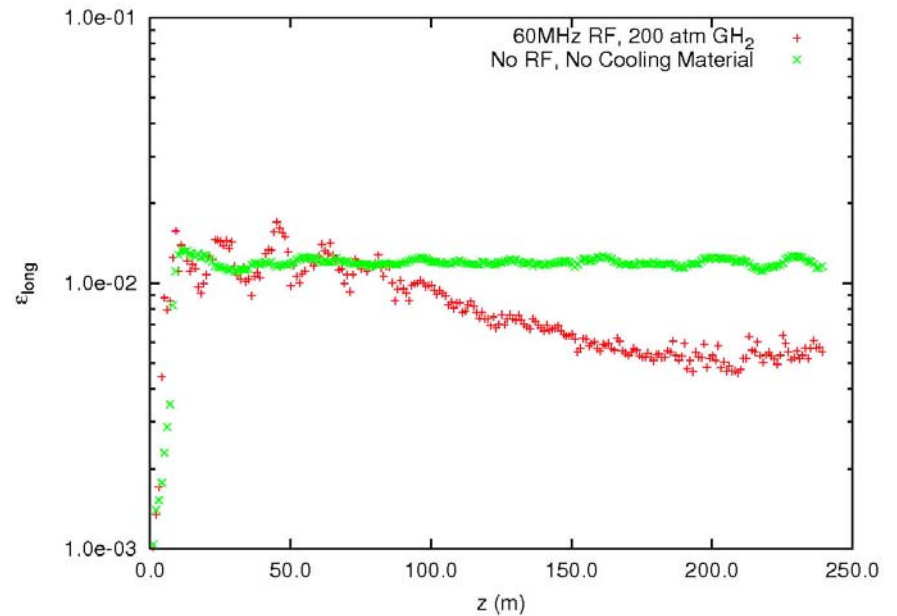

Understanding this behavior and the complex longitudinal motion seen in both ICOOL and G4BL are the problems of the moment

Status of 6D cooling project

- Interesting Ph I analytic, simulation results
 - PRSTAB paper, MuCool Note 248 is preprint
 - ICOOL and GEANT4 HCC simulations under study; cooling and RF behavior a puzzle
 - Precooling-without-RF study of HCC started
- Phase II proposal submitted (last week)

Project 3 Cryogenic Pulse Compressors

Ph I, Dave Finley, Fermilab

These are seven foot diameter spheres for 200 MHz

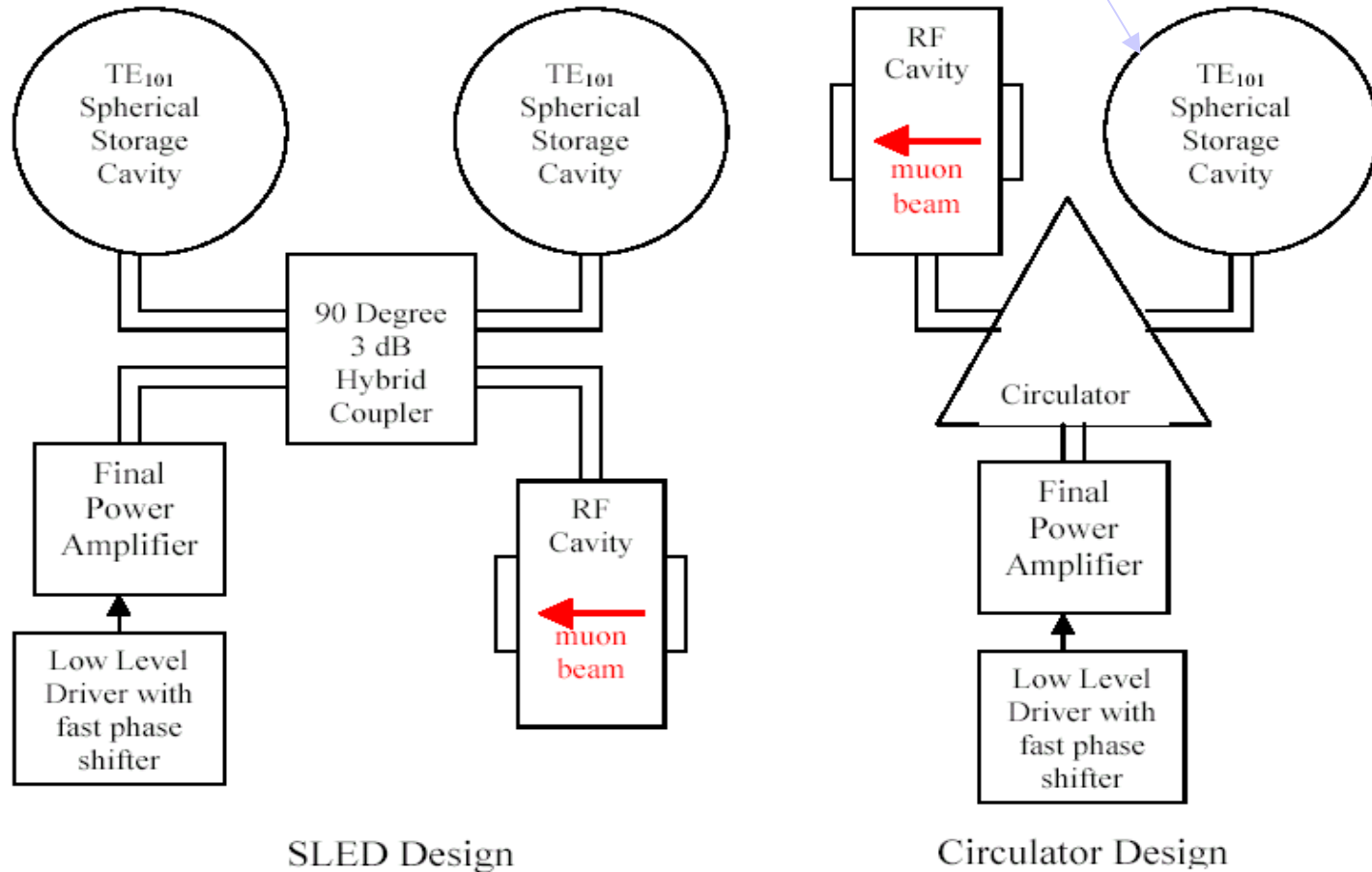

Figure 1. A comparison of the SLED and Circulator designs.

Status of Cryogenic Pulse Compressor Project

- Principles developed for >50 MV/m
@200MHz
 - Two compression schemes to get power compression by a factor of 7, or voltage by $\text{SQRT}(7)=2.65$
 - Cold RF increases voltage by (resistivity ratio) $^{1/4}=1.68$
 - Voltage thus increased by $(4.45 * 15) = 66.7$ MV/m

New 2004 Proposal

MANX Muon Collider And Neutrino Factory eXperiment
Ph I, w Dave Finley, Fermilab



- Hi-Pressure GH2
- Continuous Absorber
- Continuous low- β
 - Single-flip Solenoids
- Internal Scifi detectors
 - Minimal scattering
- MANX follows MICE
 - Engineering proof

MANX comparison to MICE

- Conventional LH2 cooling channel
 - Liquid hydrogen absorbers between RF cavities
 - Placed at low β locations, where solenoidal fields change direction
- Proposed GH2 cooling channel
 - Continuous dense hydrogen absorber fills RF cavities
 - Low β is continuous along channel

MICE

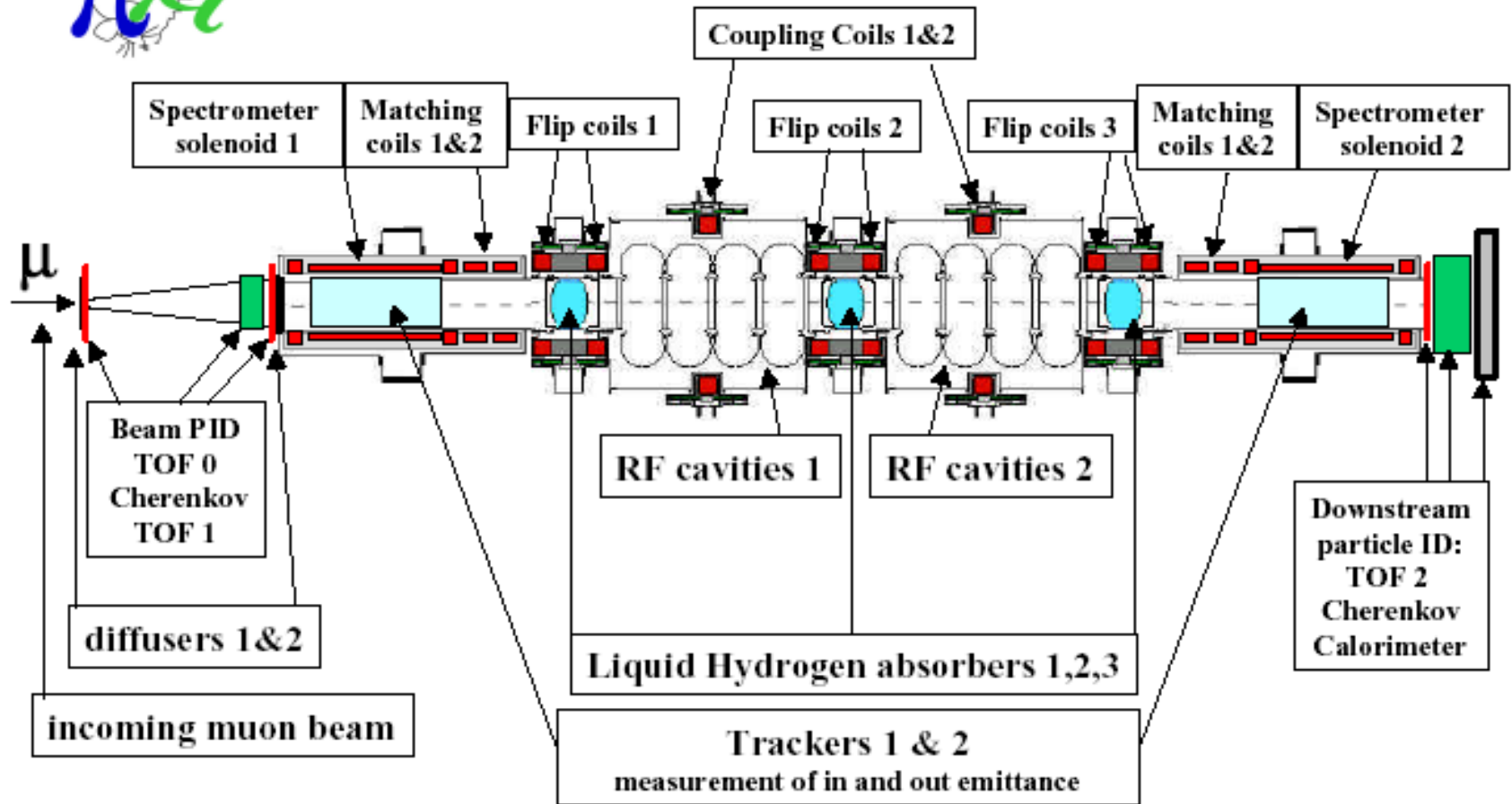

MANX is GH2 version of MICE

MANX

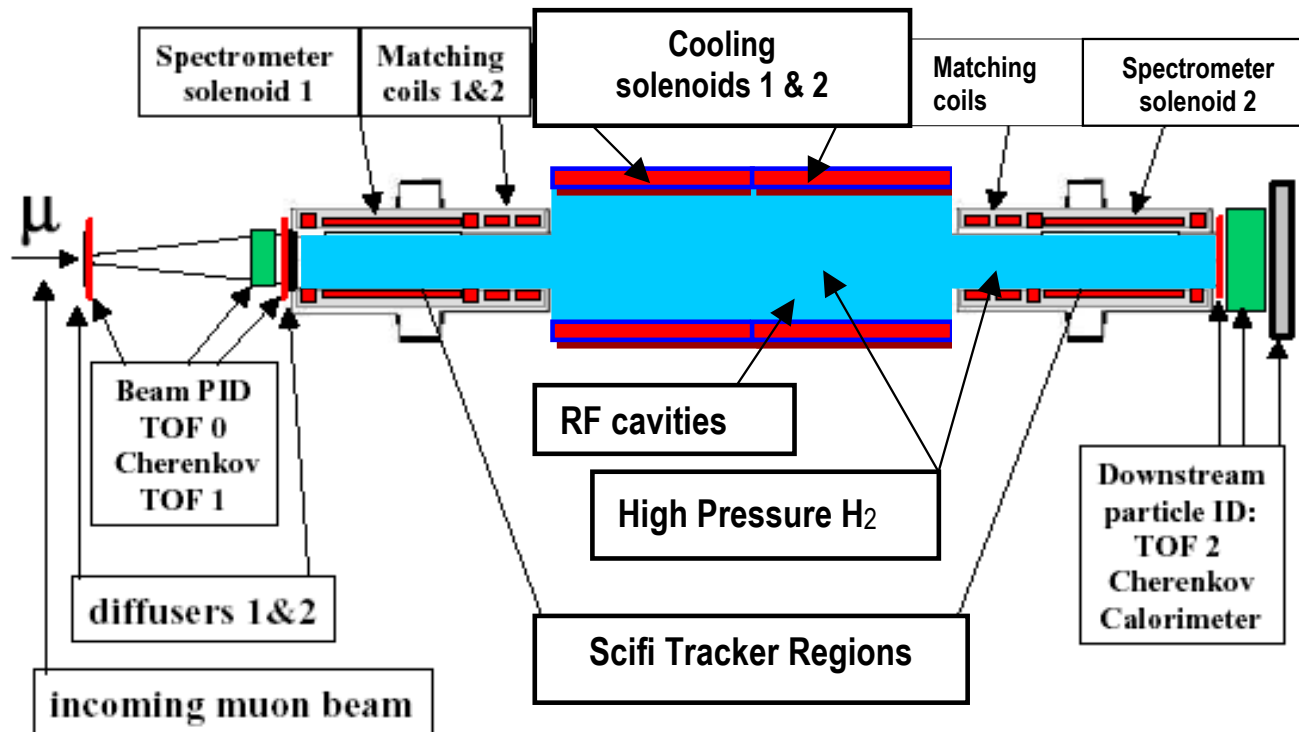

New 2004 Proposal

Hydrogen Cryostat

w Dave Finley, Fermilab

- simultaneously refrigerate
 - 1) HTS magnet coils
 - 2) cold copper RF cavities
 - 3) hydrogen gas heated by the muon beam
- extend use of hydrogen to that of refrigerant
 - besides breakdown suppressant and energy absorber
 - large amount of hydrogen for IC anyway
- relevance for hydrogen economy
 - Dr. Moyses Kuchnir

HTSC I, B, T

APPLICATIONS



B. A. Glowacki

Applied Superconductivity Research - University of Cambridge

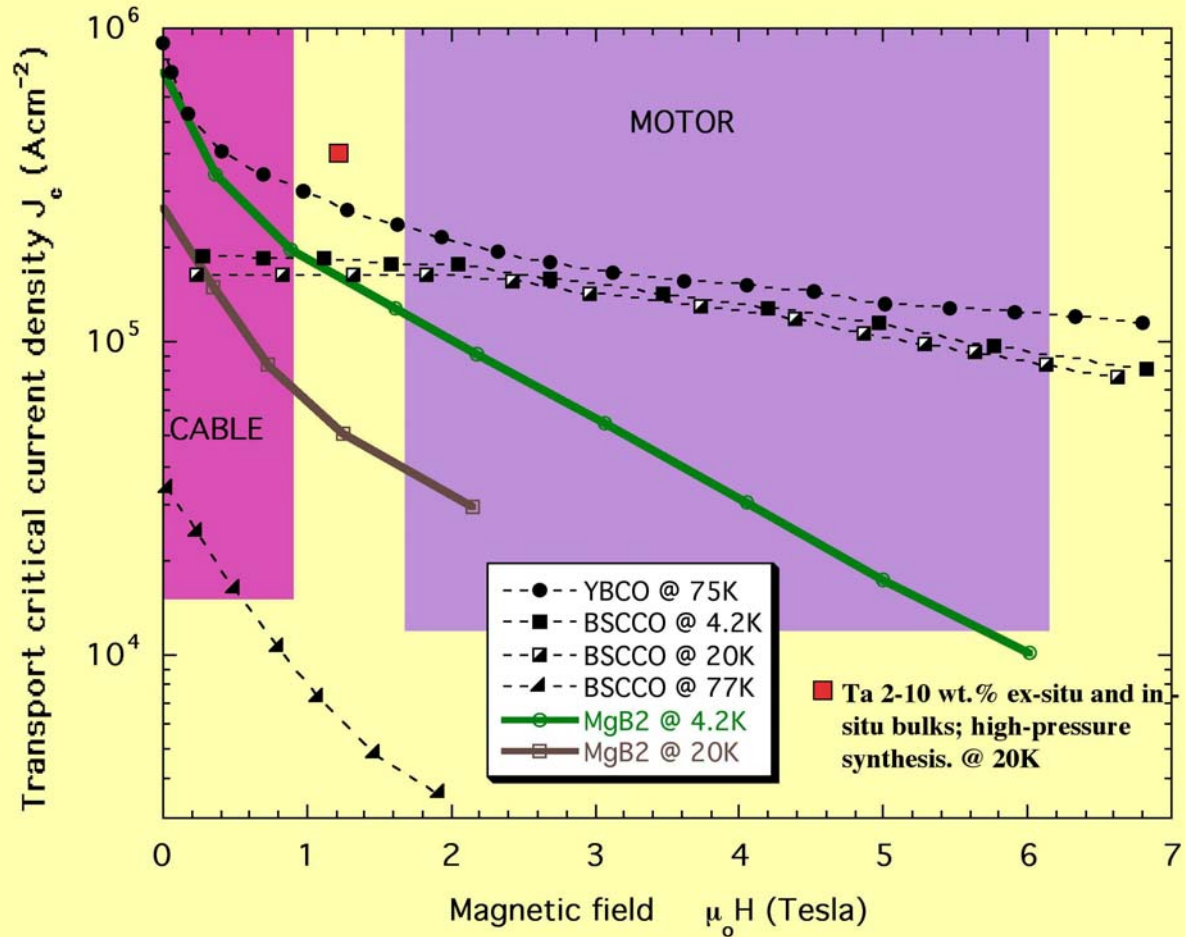

Hydrogen Cryostat

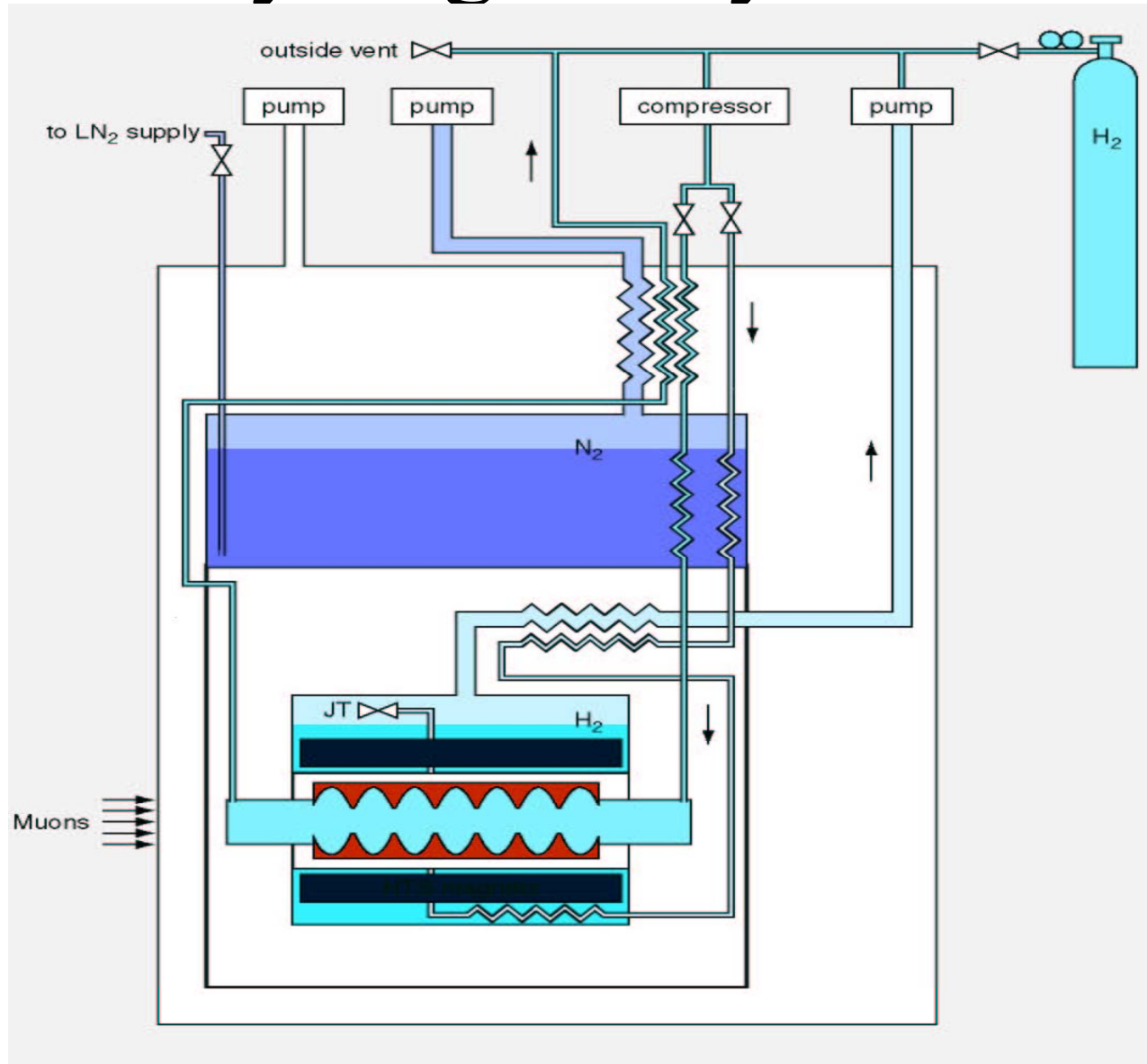

New 2004 Proposal

Phase Ionization Cooling (PIC)

Slava Derbenev, JLab

- Derbenev: 6D cooling allows new IC technique
- PIC Idea:
 - Excite parametric resonance (in linac or ring)
 - Like vertical rigid pendulum or $\frac{1}{2}$ -integer extraction
 - Use $xx' = \text{const}$ to reduce x , increase x'
 - Use IC to reduce x'
- 1 to 2 orders smaller emittance than usual IC
 - Fewer muons needed for high luminosity MC
 - Easier proton driver and production target
 - Fewer detector backgrounds from decay electrons
 - Less neutrino-induced radiation

Hyperbolic phase space motion

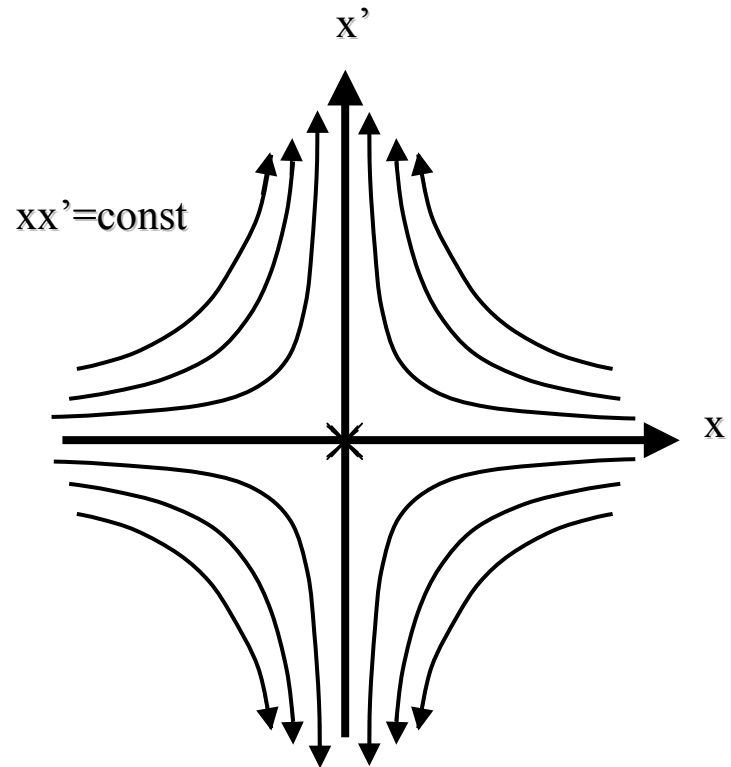
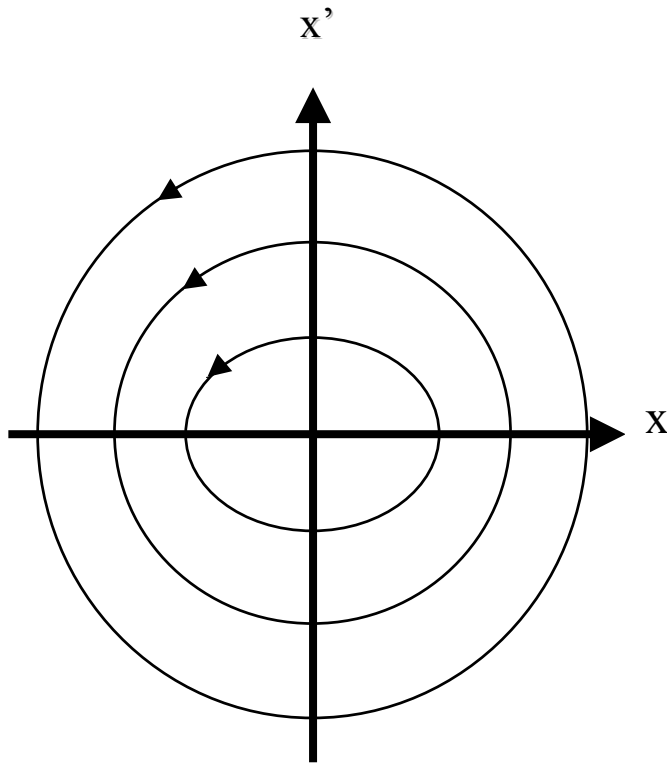
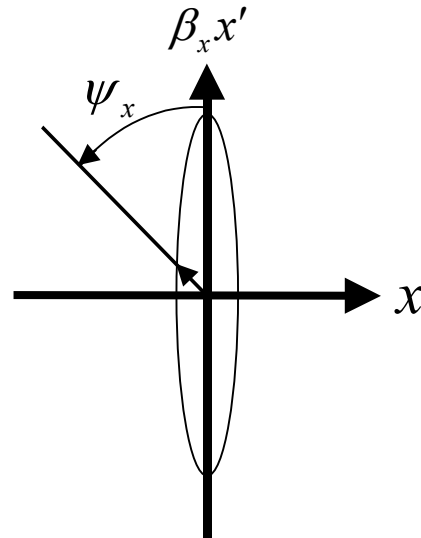
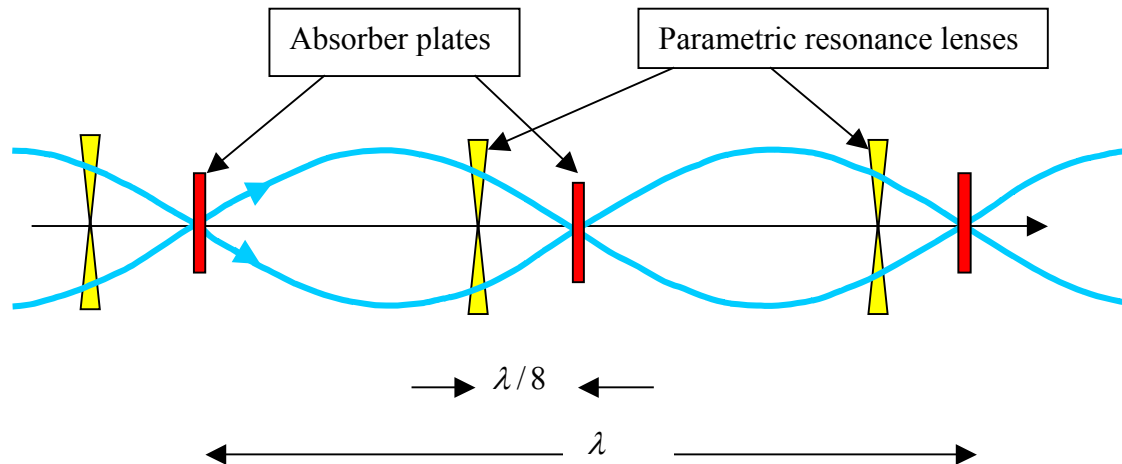

Fig. 3 Phase space compression. The spread in x diminishes due to the parametric resonance motion while the spread in x' diminishes due to ionization cooling. The area of the occupied phase space ellipse is reduced as the particles are restricted to a narrow range of phase angle, ψ .



PIC concept first appears in our 2004 SBIR proposal! First paper EPAC2004, YD,RJ.

Transverse PIC schematic



Conceptual diagram of a beam cooling channel in which hyperbolic trajectories are generated in transverse phase space by perturbing the beam at the betatron frequency, a parameter of the beam oscillatory behavior. Neither the focusing magnets that generate the betatron oscillations nor the RF cavities that replace the energy lost in the absorbers are shown in the diagram.

The longitudinal scheme is more complex.

Summary

- SBIR/STTR can support a vigorous R&D effort
 - Innovation requirement demands creativity
 - Scientific interests well-served
 - Government---expands project choices with most value
 - Academic---leads to best projects, support of researchers
 - Business---allows small business to take part in big science
- GH2 an enabling technology for μ machines
 - HG RF for less-expensive, more efficient beam cooling
 - Takes advantage of unique properties of muons
 - Emittance exchange with homogeneous absorber
 - 6D Cooling makes Muon Collider possible, maybe PIC
 - Less expensive acceleration for Neutrino Factory